



BALDER Junior Non Stander

Name:	Size
First name:	Weight
Address:	Date:
Zip code:	Salesman:
City:	Cell phone:
Tel.:	
Fax:	Diagnosis:
E-mail:	Contact from:
B-Day:	Signature:

Insured by:	
--------------------	--

Quote to:	
------------------	--

Model	Description	X	Price
Item number	Description		
BA20071002JNS	Balder Junior Non Stander Base Code: KO861		8.650,00
hp200710012	Balder Liberty Non Stander Base Code: KO836		8.650,00
hp1240	different colour covers (Red, Blue, Teal Green)		
BA1092401	Multi Seat Function Control Unit Code: E2311	x	2.650,00
hp10924	Joystick, G90A Code: E2399		1.478,00
hp10925	Joystick, G90T (Toggle switches) Code: E2399		1.478,00
hp20071073	Joystick fastner swing away G90A/T Code: E1028		292,00
	mounted left hand side		
	mounted right hand side		
hp1220030	2 Batteries Code: E2361		528,00
hp20071014	Powered tilt function 45/15 degrees Balder F/L/J Code: E1002		5.995,00
hp20071009	Powered Recline Balder F/L/J Code: E1004		7.350,00
hp20071010	Manual Recline Balder F/L/J Code: K0108		1.530,00
BA20071049	Manual Leg Rest Junior Code: K0052		1.295,00
BA20071050a	Power Elevating Leg Rest		2.395,00
BA20071051	Power Telescoping Leg Rest 4" travel Code: E1028		1.899,00
hp20071052	Power Telescoping Leg Rest 6" travel Code: E1028		1.899,00
hp20071053	Power Telescoping Leg Rest 8" travel Code: E1028		1.899,00
	including two single footplates and calf pads		
BA20071003	Power Seat lift (only if no other functions are chosen) Code: E2300		3.450,00
hp20071059	Single foot platform Code: K0042		249,00
hp20071315	Wheels for footrests Code: K0108		160,00
	Comfort Back		
BA20071241	Back Junior H: 15 3/4, W:11 3/4 Code: E2620		395,00
BA20071244	Back Junior H: 16 1/2, D:13 3/4 Code: E2620		395,00
	Custom Back Measures: (provide measurement) Code: E2617		
	Comfort seat		
BA20071235	Seat Junior W: 11 3/4, D:13 3/4 Code: E2601		345,00
BA20071238	Seat Junior W: 13 3/4, D:15 3/4 Code: E2601		345,00
	Custom Seat Measures: (provide measurement) Code: E2609		



hp20071146	Removable Head Rest Bracket	Code: E1028	212,00
hp20071148	Head rest small pad	Code: E0955	378,00
BA20071044	Armrest, flip up, height adjustable Junior	Code: E0973	375,00
	Choose armrest pad length		
	11" Length	Code: K0019	
	14" Length	Code: K0019	
	17" Length	Code: K0019	
	Special Drive Controls		
BA20071069	Attendant Control Unit		1.958,00
hp20071062	Sip & Puff		4.698,00
hp20071063	Chin Control		4.698,00
hp20071064	Head Control		4.698,00
	Accessories		
hp20071094	Lights front, rear Balder	Code: K0108	390,00
hp20071095	Lights front, rear with indicators Balder	Code: K0108	390,00
hp20071145	Pushhandle seat back Balder	Code: E1028	606,00
hp20071101	Retractable Seat Belt Auto	Code: E1028	185,00
hp20071106	Chest Strap (Velcro)	Code: E0960	62,00
hp20071089	Tray swingaside right Junior	Code: E0950	598,00
hp20071090	Tray swingaside left Junior	Code: E0950	598,00
hp20071081	Tray swingaside right small Junior	Code: E0950	598,00
hp20071082	Tray swingaside left small Junior	Code: E0950	598,00
hp20071117	Lateral Supports (4" & 6")	Code: E0956	166,00
hp200711171	Adjustable/Removable Lateral Support Hardware	Code: E1028	224,00
hp20071125	Knee & Hip Support (Adjustable Hardware)	Code: E1028	342,00
hp200711251	Knee & Hip Support Pads (4" & 6")	Code: E1028	166,00
hp20071080	Clamp down unit, undercarriage for car seat		850,00
BA20071075	Balder Docking Unit incl. Spigot		2.693,00
hp20071076	Spigot for clamp down unit (TYPE IN AMOUNT)		650,00
hp20071079	EZ-Lock for wheelchair		1.693,00
hp20071143	Ventilator tray, W: 11 3/4", D: 9 3/4"	Code: E1029	650,00



Order number

Armrest right height adjustable

Armrest left height adjustable

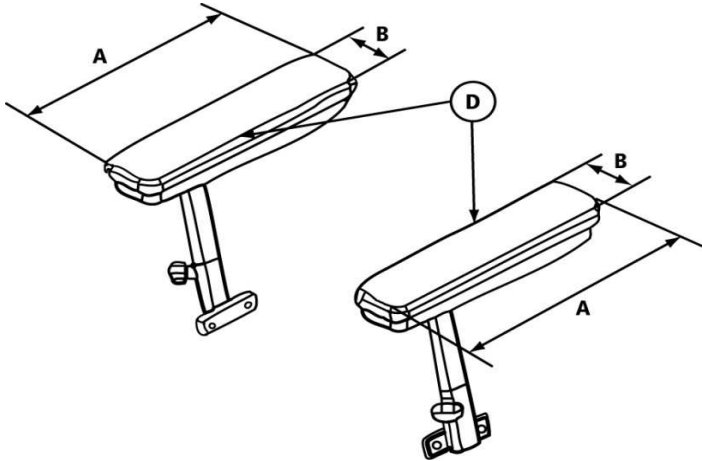

Pos	J230,J235		Measurement
A	11 3/4"		
B	3"		
D	Rubber		

Notes:

Headrest Balder Junior

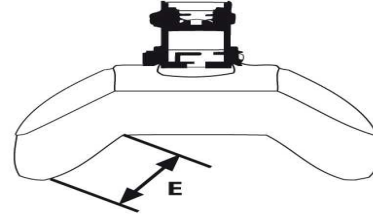
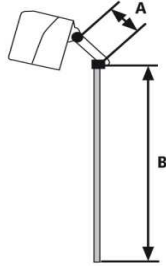
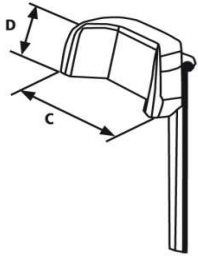

Pos	Junior	Needed Measurement
A	2 1/4"	
B	10 1/4"	
C	7"	
D	3 1/2"	
E	2 1/4"	

Notes:



Manual footrest removable - right side
Manual footrest removable - left side
Electrical footrests

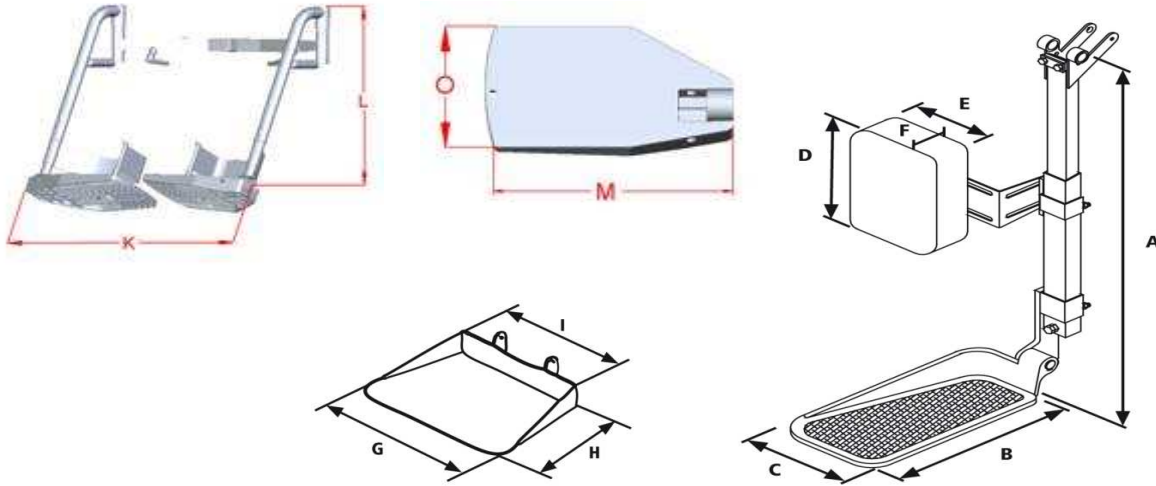

Pos	Standard	Needed measurement
L	13" - 21 1/2"	
K	19" - 25 1/4"	
M	7 1/4"	
O	5"	
Pos	Standard	Needed measurement
A	13" - 20 1/2"	
B	6 1/4"	
C	5 1/2"	
D	6 1/4"	
E	5 1/4"	
F	1 1/4"	
G	12 1/4"	
H	6 3/4"	
I	10 1/4"	

Notes:

Back Junior

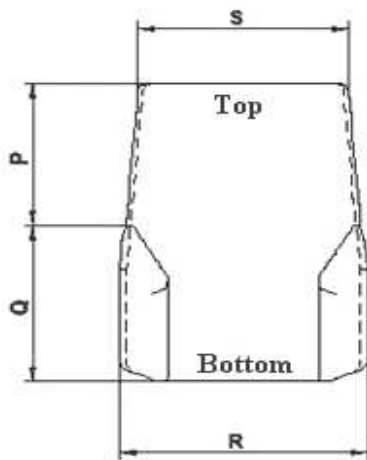
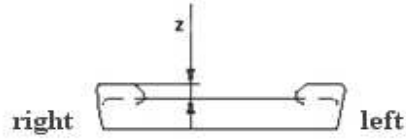

Pos	1	2	Needed Measurement
Z	3/4"	3/4"	
P	6 3/4"	7 1/2"	
Q	9"	9"	
R	11 3/4"	13 3/4"	
S	10 1/4"	12"	

Notes:

Seat Junior

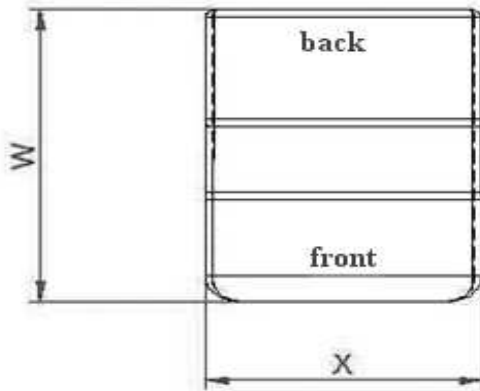
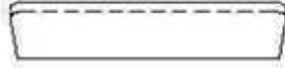

Pos	1	2	Needed Measurement
W	13 3/4"	15 3/4"	
X	11 3/4"	13 3/4"	

Notes: